

stellar dust

Design by
CMC Architects, Václav Mlynář and Jakub Pollág

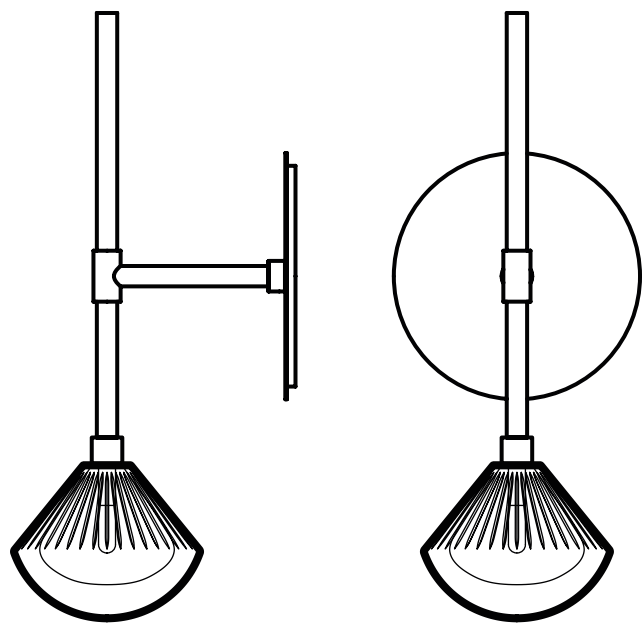

bomma

bomma.cz

TECHNICAL SHEET
FOR WALL LIGHT FIXTURES

STELLAR DUST wall

Design by
CMC Architects, Václav Mlynář
and Jakub Pollág

Handmade glass attributes

All Bomma products are hand-made from mouth-blown lead-free crystal. Therefore any small bubbles, non-melts and irregularities in the glass are both proof and a characteristic feature of this traditional craft

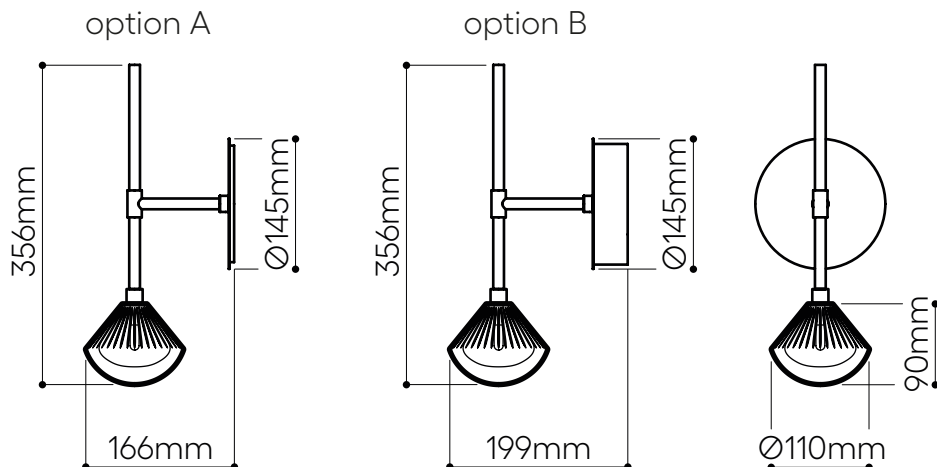

LIGHTING DESCRIPTION

Size	110 x 166 (199) x 356 mm 4,3 x 6,5 (7,8) x 14 inch
Weight	+ - 1,6 kg / 3,53 lbs
Glass	clear lead-free crystal
Mounting	brushed gold (brushed brass)
Recommended junction box	EU - A.UK1-SH (72mm dia, 60mm min. depth) UL/The Americas - electrical box, Octagon, 4 X 4 inch (1,4 inch min. depth)
Protection	IP 20
Nominal voltage	220-240V / A.C. 50 hz (EU) 110-120 V / A.C. 60 Hz (USA)
Class	II. EU / I. USA

LIGHT SOURCE

Type	G4, 1,2W LED, 100 lm
Base	G4 (EU) / G4 (USA)
Voltage	12VDC, 100mA
Temperature	2700 K
Color index	RA 90+
Dimming	EU/Other versions - non-dimmable UL/The Americas - TRIAC, ELV

TRANSFORMER

Primary circuit	100-240V, 50/60 Hz,
Secondary circuit	12VDC, + -0,5A, 5W

PACKAGING

Material	Cardboard
Size	220 x 220 x 250 mm 8,6 x 8,6 x 9,8 inch
Origin:	traditionally produced in the Czech Republic
Intellectual property license holder:	Bomma Czech Republic (EU)
Represented by	BMRC group s.r.o.

CERTIFICATES

